

CONFIGURATION DETAIL

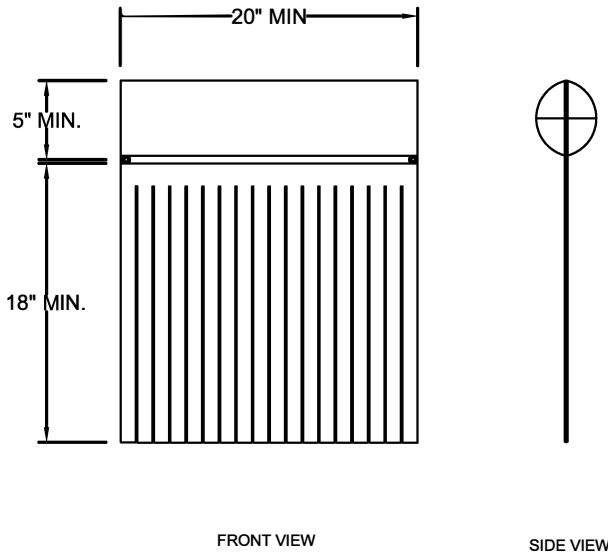

BIO-SKIRT ANTI-MICROBIAL AND HYDROCARBON ADSORBING SKIRTED BOOM

TYPICAL INSTALLATION

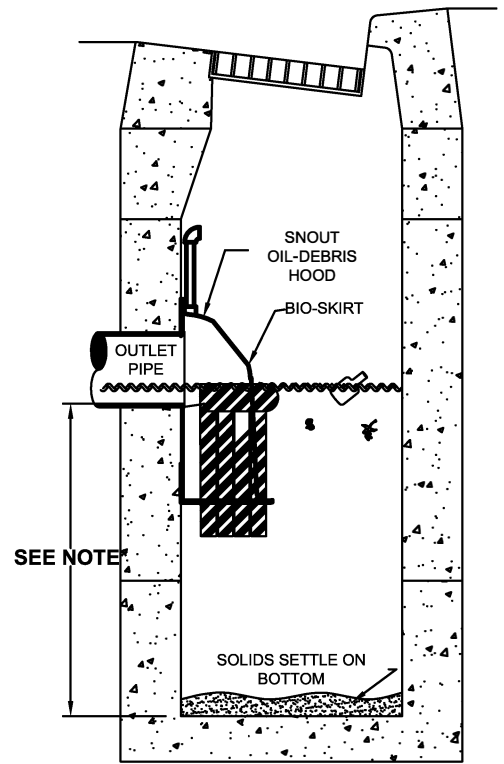

*NOTE- ATTACH BIO-SKIRT STRUCTURE WALL SUCH THAT IT IS APPROXIMATELY AT SAME ELEVATION AS STATIC WATER LEVEL

NOTES:

- All new and/or existing catch basins or water quality structures shall be outfitted with the Bio-Skirt(R) Bacteria and Hydrocarbon reducing skirted boom as manufactured by: BEST MANAGEMENT PRODUCTS, INC. 53 MT. ARCHER RD. LYME, CT 06371 (860) 434-0277, (860) 434-3195 FAX TOLL FREE: (800) 504-8008 OR (888) 434-0277 WEB SITE: www.bmpinc.com or pre-approved equal.
- The skirted boom shall be comprised of an upper boom portion that is an adsorbent fabric covered floating boom of 5" minimum diameter with an integral lower skirt portion comprised of fabric tendrils of an 18" minimum length that hang beneath the boom.
- All booms shall be made from geo-textile quality needle-woven filtration fabric manufactured from 100% recycled select fibers with a .125" minimum thickness.
- All fabric shall be treated with a covalently surface bonded non-leaching antimicrobial agent and booms shall display a tag indicating "Antimicrobial".
- The Bio-Skirt shall be positioned in front of the exit pipe and SNOUT® Oil-Debris Separator if so equipped (the preferred application of the Bio-Skirt is to be deployed with the SNOUT).
- The skirted boom shall be securely attached to the structure wall on each side of the exit pipe with 3/8" stainless steel bolts, stainless steel tabs, plastic-composite hooks and elastomeric cord as found in manufacturer supplied in installation kit.
- For applications where multiple Bio-Skirts are deployed together for larger SNOUTs (e.g. on 24" and larger SNOUTs per schedule below*), connect skirts grommet to grommet with hooks and cord as supplied in the installation kit.

Typical Deployment Schedule:
 12-18" SNOUT- One Bio-Skirt
 24-30" SNOUT- Two Bio-Skirts
 36-52" SNOUT- Three Bio-Skirts
 72" and up, Call 800-504-8008 for guidance.



(317) 346-4110
 www.drainagesolutionsinc.com

SNOUT US Patent # 6126817

INSTALLATION DETAIL

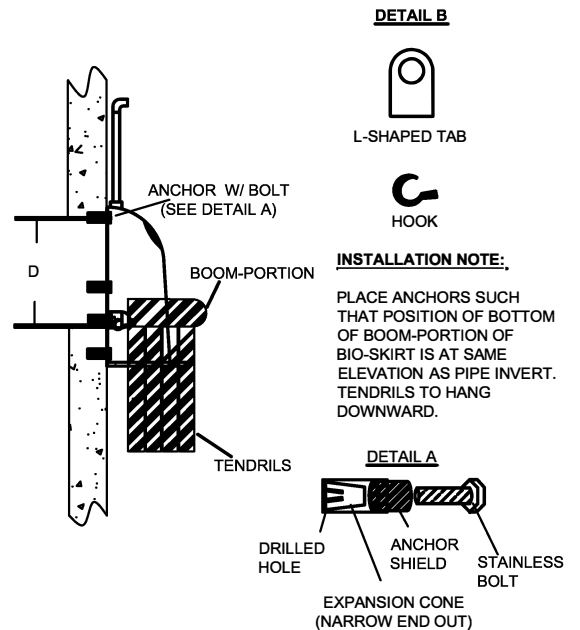

ANTI-MICROBIAL AND OIL ADSORBENT SPECIFICATION FOR CATCH BASINS AND WATER QUALITY STRUCTURES

DESCRIPTION BIO-SKIRT (TM) SPECIFICATION AND INSTALLATION (TYPICAL)	DATE	SCALE
	08/08/07	NONE
DRAWING NUMBER SP-BIO		